

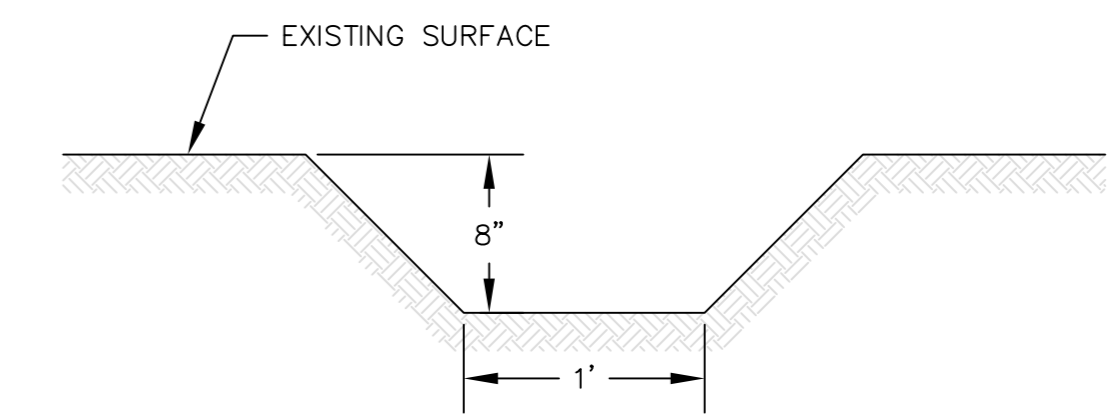

NOTES:

1. THE RECOMMENDATION FOR THIS SITE IS A SERIES OF INFILTRATION PONDS THAT CONNECT TO EACH OTHER AND CONNECT THROUGH A SERIES OF SWALES.
2. THE PONDS COLLECTIVELY ARE DESIGNED TO HOLD AND INFILTRATE UP TO THE 25 YEAR STORM. ANY VOLUME OF STORMWATER THAT EXCEEDS THAT VOLUME WILL BE CHANNLED THROUGH THE INFILTRATION PONDS AND OUT THE EMERGENCY SPILL WAY.
3. THE APPROXIMATE DRAINAGE AREA FOR THE PROPOSED INFILTRATION PONDS IS 9.29 ACRES. THE INFILTRATION PONDS WILL ONLY COLLECT RUN OFF FROM THE GOLF COURSE GROUNDS; THEY ARE NOT CONNECTED TO ANY EXISTING STORMWATER SYSTEM.
5. THE INFILTRATION PONDS HAVE THE POTENTIAL TO INFILTRATE AN ADDITIONAL 563,684 GALLONS OF WATER BACK INTO THE AQUIFER PER STORM.
6. ON AVERAGE THE PROPOSED INFILTRATION SYSTEM WILL INFILTRATE 6,788,317 GALLONS OVER THE COURSE OF ONE YEAR. OBVIOUSLY THIS NUMBER WILL VARY WITH THE INTENSITY OF THE STORMS AND THE AMOUNT OF RAIN.
7. IT IS RECOMMENDED THAT A LANDSCAPE ARCHITECT ASSIST IN THE FINAL DESIGN OF THE INFILTRATION PONDS SO THEY WILL BLEND IN WITH THE SURROUNDINGS OF THE GOLF COURSE AND NOT BE SEEN AS AN EYE-SORE OR LOWER THE VALUE OF THE PROPERTY.
8. THIS IS NOT FOR PERMITTING OR CONSTRUCTION USE, THIS DRAWING IS ONLY TO BE USED FOR CONCEPTUAL PURPOSES.



TYPICAL CROSS SECTION OF SWALE  
(NOT TO SCALE)

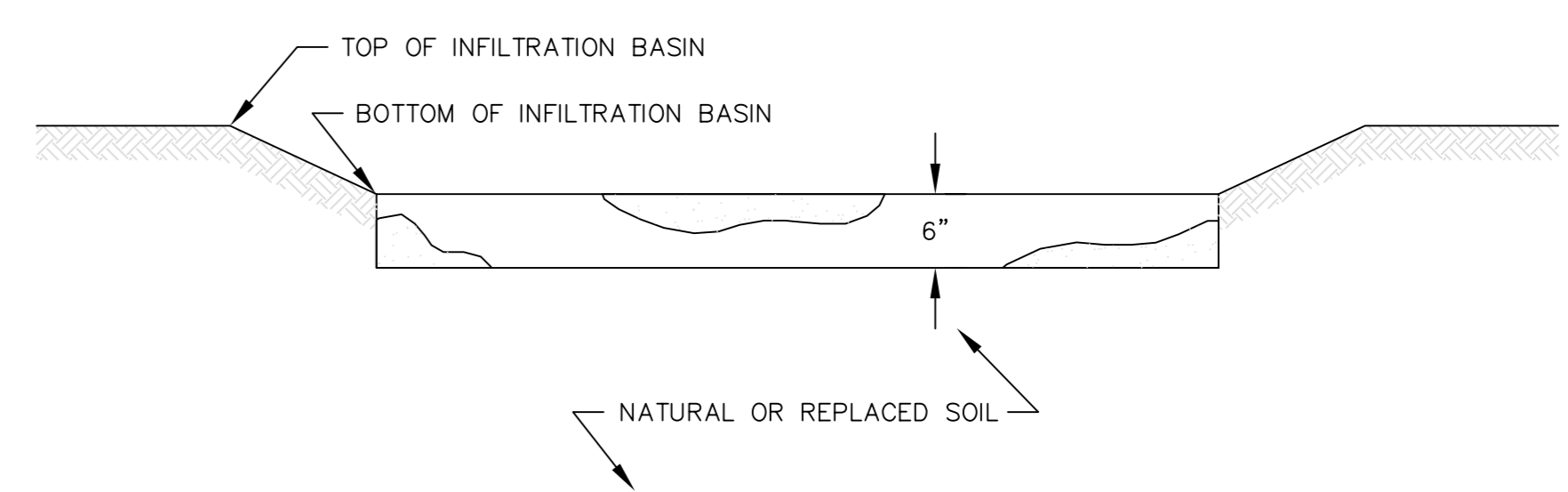

TYPICAL CROSS SECTION OF INFILTRATION BASIN  
(NOT TO SCALE)

LEGEND

- PROPOSED DRAINAGE AREA
- PROPOSED INFILTRATION BASINS
- PROPOSED SWALES

<b>CHRISTOPHER C. OBROPTA, Ph.D., P.E.</b> PROFESSIONAL ENGINEER - NJ LICENSE # 37532	
DESIGNED	DATE
CHECKED	DATE
APPROVED	DATE
XXX	XXX
<b>MILESTONE 4 OF REGIONAL STORMWATER MANAGEMENT PLAN FOR THE          ROBINSON BRANCH          NEW JERSEY DEPARTMENT OF ENVIRONMENTAL PROTECTION          SHACKAMAXON GOLF COURSE          INFILTRATION BASIN CONCEPT PLANS</b>	
JOB	SHEET #
XXXXX	XX
XX	XX